



WHI 20-MINUTE FIREGUARD PLUS FGH WRAP AROUND JAMB INSTALLATION INSTRUCTIONS

- Maximum door opening:** Single 4'-0" X 9'-0" / Pair 8'-0" X 9'-0"
Maximum overall opening: Max door opening plus thickness of jamb equals jamb buck opening
Wall depth: 3-3/4" (2-1/2" stud plus 5/8" drywall both sides)
Wall type (rough opening): Metal or wood stud
-

- Jamb is installed with 1-1/8" long drywall screws thru metal stud in pairs into the back of the jamb member or nailed thru the wood stud in pairs into the back of the jamb member with 8d nails. Nails must penetrate the jamb 1" deep. Fasteners are to be a maximum of 4" from each end and spaced a maximum of 12" O.C
- Jamb may also be nailed thru the face with 10d finish nails staggered and spaced a maximum 4" from each end and 12" O.C.
- Jamb must overlap drywall by 1/2" minimum on both sides of the wall.
- Jamb is intended to be installed without shim space before or after drywall is installed, studs should be plumb and squared before jamb installation.

OPTIONAL SHIMMING: Maximum shim space is 1/4". Shims are required at each hinge and strike location. If jamb requires shimming, back plow on the jamb member is required to be 3/4" deep and jamb thickness can be no less than 3/4". This can be performed by a WHI machinist licensed to machine Eggers WHI jams. *See attached drawings*

T-STOP: Minimum 1/2" thick X 1-1/2" wide. T-stops are installed with 6d finish nails spaced maximum 2" from each end and 12" on center.

CORNER JOINT: Jamb can be machined for dowels or biscuits and glued at the corner joint

**Pemko HSS2000 intumescent and Pemko S88 smoke seals are required only for positive pressure and smoke control openings. (UL 10C, U.B.C. 7-2 1997)*

***Failure to install the jamb in accordance with these installation instructions voids the label.*



WHI 20 MINUTE FIREGUARD PLUS FGH HEADER/JAMB

- FRAME WITHOUT SHIM SPACE
- ALL DIMENSIONS SHOWN ARE MINIMUMS
- WOOD OR METAL STUD, WOOD STUD SHOWN

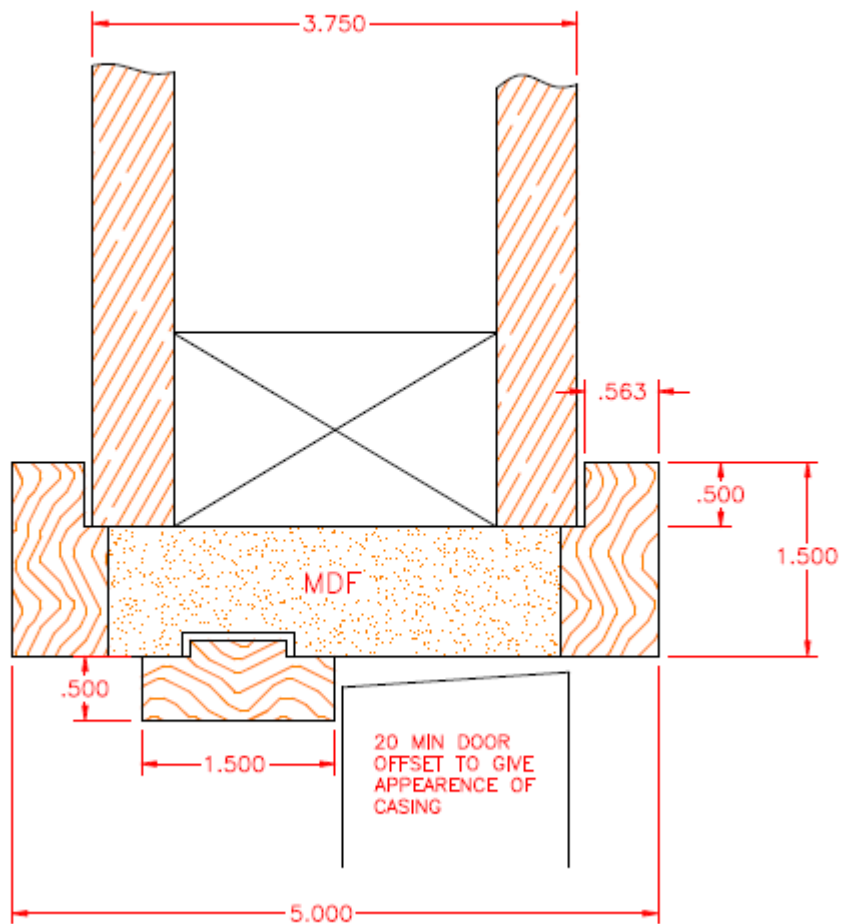

WHI 20-Minute Fireguard Plus FGH Wrap Around Jamb

Installation Instructions



Eggers Industries

No. 930-10-09

WHI 20 MINUTE FIREGUARD PLUS FGH HEADER/JAMB

- FRAME WITH SHIM SPACE (1/4" MAX)
- ALL DIMENSIONS SHOWN ARE MINIMUMS
- WOOD OR METAL STUDS, METAL STUD SHOWN

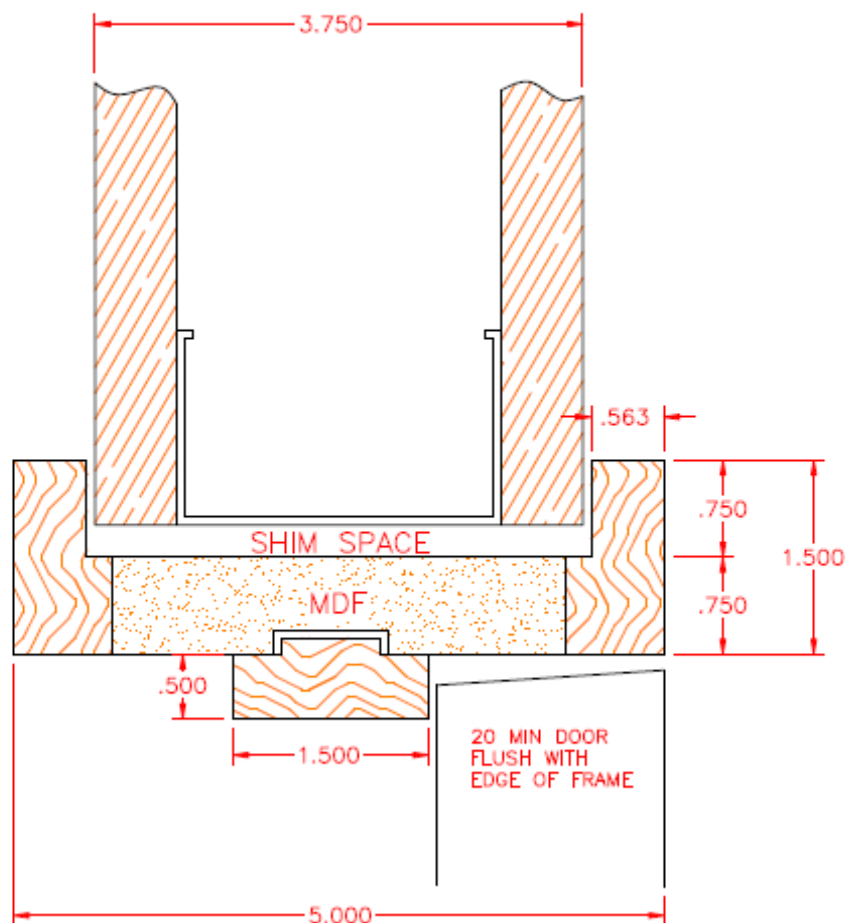

Stile & Rail Doors, Door Frames,
Plywood, Veneered Components

Two Rivers Division
One Eggers Drive
Two Rivers, WI 54241
Phone: 920.793.1351
Fax: 920.793.2958

www.eggertindustries.com

Flush Doors

Neenah Division
164 North Lake Street
Neenah, WI 54956
Phone: 920.722.6444
Fax: 920.722.0357

email: sales@eggertindustries.com